

PIPE RECOVERY TOOLS

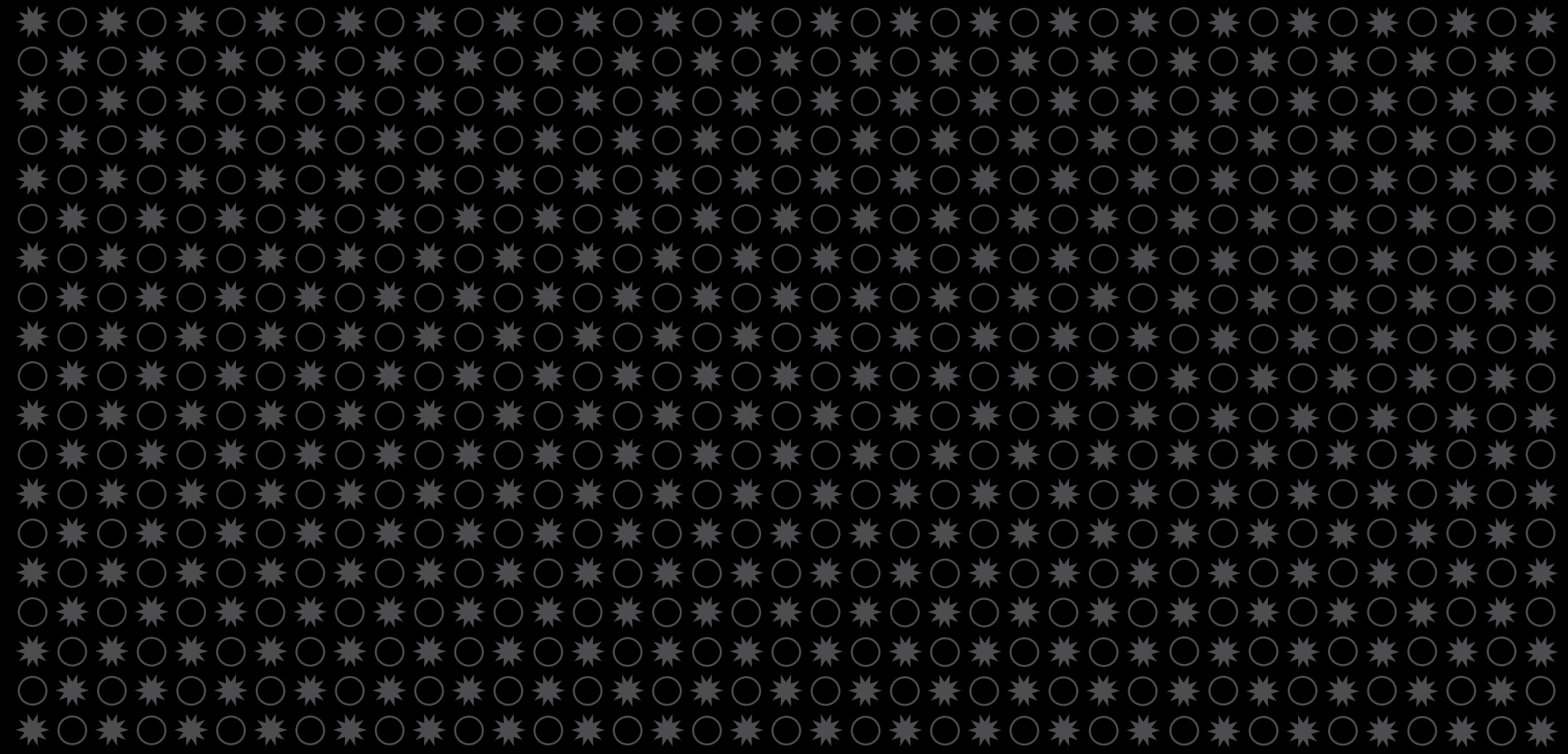

COILED TUBING CUTTERS

Description	Part No.	Cutter OD (in)	Rating (psi / °F)	Explosive Weight (g)	Housing Material	Shipping Class	Recommended Target	Wall Thickness	Weight lb./ft. (Incl Coupl.)	
1.25" 0.948" Coiled Tubing Cutter	100118389	0.948	10,000/325	2.9	Steel	1.4D UN0440	1.25"	N80	0.095	1.172
1.50" 1-3/16" Coiled Tubing Cutter	100000429	1.188	10,000/325	4.7	Steel	1.4D UN0440	1.50"	N80	0.109	1.619
1.75" 1-3/8" Tubing Cutter	100000569	1.375	15,000/400	4	Steel	1.4D UN0440	1.75"	N80	0.134	2.313
1.90" 1-3/8" Tubing Cutter	100000569	1.375	15,000/400	4	Steel	1.4D UN0440	1.90"	P105	0.145	2.900

ACCESSORIES				SAFETY ACCESSORIES			Notes: 1. Always run effective centralization for optimum results. 2. Undersized cutters may not make full cut. 3. When more than one cutter is available for the specification, always select the largest diameter cutter.
55 Ohm Detonator - Resistorized	100010855			Safety Tube for Detonator	100158234		
5/8" OD Cont Sub (1.59 cm)	100005498	0.5-20 UNF-2A (thread)		5/8 in. Shunt Plug	100158235		
3/4" OD Cont Sub (1.91 cm)	100158243	0.555-28P-36-SA (thread)		3/4 in. Shunt Plug	120042542		
1" OD Cont Sub (2.54 cm)	100014497	0.812-16 UN-2A (thread)		1-in. Shunt Plug	120042541		

TUBING CUTTERS

2-3/8" 1-11/16" Tubing Cutter	100000352	1.688	20,000/400	8.5	Ceramic	1.4D UN0440	2-3/8"	P105	0.190 - 0.254	4.70 - 5.95
2-3/8" 1-11/16" Tubing Cutter (Cast Iron)	101288527	1.688	12,500/400	8.5	Cast Iron	1.4D UN0440	2-3/8"	P105	0.190 - 0.254	4.70 - 5.95
2-3/8" 1-23/32" Tubing Cutter	100000570	1.719	20,000/400	8.5	Ceramic	1.4D UN0440	2-3/8"	P105	0.190 - 0.254	4.70 - 5.95
2-3/8" 1-13/16" Tubing Cutter	100000353	1.813	20,000/400	8.5	Ceramic	1.4D UN0440	2-3/8"	P105	0.190 - 0.254	4.70 - 5.95
2-3/8" 1-13/16" Tubing Cutter (Cast Iron)	101290400	1.813	12,500/400	8.5	Cast Iron	1.4D UN0440	2-3/8"	P105	0.190 - 0.254	4.70 - 5.95
2-7/8" 2-1/32" Tubing Cutter	100000354	2.031	20,000/400	15.4	Ceramic	1.4D UN0440	2-7/8"	P105	.217 - .308	6.50 - 8.70
2-7/8" 2-1/8" Tubing Cutter	100000355	2.125	20,000/400	15.4	Ceramic	1.4D UN0440	2-7/8"	P105	.217 - .308	6.50 - 8.70
2-7/8" 2-1/8" Tubing Cutter (Cast Iron)	101290402	2.125	12,500/400	15.4	Cast Iron	1.4D UN0440	2-7/8"	P105	.217 - .308	6.50 - 8.70
2-7/8" 2-1/8" Hastelloy Tubing Cutter	100000430	2.125	20,000/400	33	Ceramic	1.1D UN0059	2-7/8"	Chrome	0.276	7.90
2-7/8" 2-1/4" Tubing Cutter	100000356	2.250	20,000/400	13	Ceramic	1.4D UN0440	2-7/8"	P105	0.217 - 0.276	6.50 - 7.90
2-7/8" 2-1/4" Tubing Cutter (Cast Iron)	101290405	2.250	12,500/400	13	Cast Iron	1.4D UN0440	2-7/8"	P105	0.217 - 0.276	6.50 - 7.90
3-1/2" 2-1/2" Tubing Cutter (Cast Iron)	101290406	2.500	12,500/400	22.5	Cast Iron	1.4D UN0440	3-1/2"	P105	0.254 - 0.449	9.30 - 15.50
3-1/2" 2-19/32" Tubing Cutter	100116367	2.594	20,000/400	22.5	Ceramic	1.4D UN0440	3-1/2"	P105	0.254 - 0.289	9.30 - 10.30
3-1/2" 2.70" Tubing Cutter	100011034	2.700	20,000/400	22.5	Ceramic	1.4D UN0440	3-1/2"	P105	0.254 - 0.289	9.30 - 10.30
3-1/2" 2.70" Hastelloy Tubing Cutter	100000431	2.700	20,000/400	46	Ceramic	1.1D UN0059	3-1/2"	Chrome	0.254 - 0.289	9.30 - 10.30

TUBING CUTTERS FOR RESTRICTED I.D.

2-3/8" 1-9/16" Tubing Cutter - Slim	102012507	1.563	20,000/400	40	Steel	1.4D UN0440	2-3/8"	N80	0.190 - 0.254	4.70 - 5.95
2-7/8" 1-13/16" Tubing Cutter - Slim	102012508	1.813	20,000/400	40	Steel	1.4D UN0440	2-7/8"	N80	0.217 - 0.308	6.50 - 8.70

ACCESSORIES FOR TUBING CUTTERS		SHIPPING CLASS	HP ACCESSORIES	
55 Ohm Detonator - Resistorized	100000432	1.4B UN0255	Extension Mandrel - Steel	101293227
Firing Head, 1-1/2" OD	100000434	N/A	Adapter for RED® - Steel	101293230
Aluminum Extension Mandrel	100008258	N/A	SAFETY ACCESSORIES	
Detonator - RED®	101272595	1.4B UN0255	Shunt Plug	100010861
Aluminum Adapter for RED® Detonator	101293676	N/A	Safety Tube	100010862

WAFER CASING AND DRILL PIPE CUTTERS

Casing OD (in.)	Description	Part No.	Cutter OD (in.)	Rating (psi / °F)	Explosive Weight (g)	Housing Material	Shipping Class	RECOMMENDED TARGET CASING			
								Casing OD (in.)	Grade	Wall Thickness	Weight lb./ft. (Incl coupl.)
3-1/2" DP	2-3/8" Drill Pipe Cutter	100116368	2.375	12,500/400	22.0	Steel	1.4D UN0440	3-1/2" DP	G105	0.254 - 0.449	9.5 - 15.5
4"	2-15/16" Drill Pipe Cutter	100127821	2.938	12,500/400	47.4	Steel	1.1D UN0059	4"	L80	0.262 - 0.380	11.85 - 15.7
4-1/2" DP	2-15/16" Drill Pipe Cutter	100127821	2.938	12,500/400	47.4	Steel	1.1D UN0059	4-1/2" DP	G105	0.271 - 0.430	13.75 - 20.00
4-1/2" DP	3-5/16" Drill Pipe Cutter	100000140	3.313	12,500/400	61	Steel/ Aluminum	1.1D UN0059	4-1/2" DP	G105	0.430	20.00
5" DP	3-5/16" Drill Pipe Cutter	102193449	3.625	7500/400	54	Steel/ Aluminum	1.1D UN0059	5" DP	G105	0.296 - 0.500	16.25 - 25.60
4-1/2"	3-5/8" Casing Cutter	102193449	3.625	7500/400	54	Aluminum	1.1D UN0059	4-1/2"	L80	0.205 - 0.337	9.50 - 15.10
5"	4" Casing Cutter	101293457	4.000	9000/400	110	Aluminum	1.1D UN0059	5"	L80	0.253 - 0.437	11.50 - 21.40
5-1/2"	4-1/2" Casing Cutter	100014494	4.500	9000/400	101	Aluminum	1.1D UN0059	5-1/2"	L80	0.304 - 0.415	17.00 - 23.00
5-1/2"	4-3/4" Casing Cutter	101293484	4.750	9000/400	101	Cast Iron/ Aluminum	1.1D UN0059	5-1/2"	L80	0.244 - 0.304	14.00 - 17.00
5-3/4"	4-3/4" Casing Cutter	101293484	4.750	9000/400	101	Cast Iron/ Aluminum	1.1D UN0059	5-3/4"	L80	0.330 - 0.430	19.50 - 25.20
6"	5-3/8" Casing Cutter	101293491	5.375	9000/400	240	Aluminum	1.1D UN0059	6"	L80	0.224 - 0.275	14.00 - 17.00
6-5/8"	5-3/8" Casing Cutter	101293491	5.375	9000/400	240	Aluminum	1.1D UN0059	6-5/8"	L80	0.475	32.00
6-5/8"	5-1/2" Casing Cutter	101293515	5.500	9000/400	253	Aluminum	1.1D UN0059	6-5/8"	L80	0.228 - 0.417	20.00 - 28.00
7"	5-1/2" Casing Cutter	101293515	5.500	9000/400	253	Aluminum	1.1D UN0059	7"	L80	0.408 - .0540	29.00 - 38.00
7"	6" Casing Cutter	101293536	6.000	9000/400	280	Aluminum	1.1D UN0059	7"	L80	0.317 - 0.408	23.00 - 29.00
7-5/8"	6-1/8" Casing Cutter	101293544	6.125	9000/400	253	Aluminum	1.1D UN0059	7-5/8"	L80	0.375 - 0.500	29.70 - 39.00
8-5/8"	7-1/4" Casing Cutter	101293553	7.250	8,000/400	373	Aluminum	1.1D UN0059	8-5/8"	L80	0.400 - 0.595	36.00 - 52.00
9-5/8"	8-3/16" Casing Cutter	101293555	8.188	8,000/400	407	Aluminum	1.1D UN0059	9-5/8"	L80	0.435 - 0.545	43.50 - 53.50

Accessories for Drill Pipe & Casing Cutters			HP Accessories (20,000 psie max.)		Notes:
55 Ohm Detonator - Resistorized	100000432	1.4B UN0255	Extension Mandrel - Steel	101293227	
Aluminum Adapter for Resistorized Detonator	100014468	N/A	Adapter for Resistorized Detonator - Steel	101293240	
Firing Head , 1-1/2" OD	100000434	N/A	Adapter for RED® - Steel	101295134	
Aluminum Extension Mandrel	100008258	N/A	Safety Accessories		
Detonator - RED®	101272595	1.4B UN0255	Shunt Plug	100010861	
Aluminum Adapter for RED® Detonator	101295128	N/A	Safety Tube	100010862	

SEGMENTED CUTTERS

Casing OD (in)	Description	Part No.	Cutter OD (in)	Rating (psi / °F)	Explosive Weight (g)	Housing Material	Shipping Class	Recommended Casing OD (in)	Target Grade	Wall Thickness	Weight lb./ft (incl. coupl.)
4	2-15/16" Casing Cutter	101978733	2.938	12500 / 400	56.9	Steel	1.4D UN0352	4	L80	0.262 - 0.380	11.85 - 15.70
4-1/2 DP 5 DP	3-5/16" Drill Pipe Cutter	101978734	3.313	12000 / 400	64.8	Steel/ Aluminum	1.4D UN0352	4-1/2 DP 5 DP	G105	0.271 - 0.430 0.296 - 0.362	13.75 - 20.00 16.25 - 19.50
4-1/2 5 5 DP	3-5/8" "Casing Cutter" 3-5/8" "Drill Pipe Cutter"	101978736	3.625	7,500 / 400	54.8	Aluminum	1.4D UN0352	4-1/2 5 5 DP	L80 G105	0.205 - 0.337 0.296 - 0.500 0.296 - 0.362	9.50 - 15.10 15.00 - 24.20 16.25 - 19.50
5	4" Casing Cutter	101978737 (Check with JRC)	4.000	9,000 / 400	N/A	Aluminum	1.4D UN0352	5	L80	0.253 - 0.437	11.50 - 21.40
5-1/2	4-1/2" Casing Cutter	101978738	4.500	9,000 / 400	114.3	Aluminum	1.4D UN0352	5-1/2	L80	0.304 - 0.415	17.00 - 23.00
5-1/2 5-3/4	4-3/4" Casing Cutter	101978739	4.750	9,000 / 400	114.3	Cast Iron/ Aluminum	1.4D UN0352	5-1/2 5-3/4	L80	0.244 - 0.304 0.330 - 0.430	14.00 - 17.00 19.50 - 25.20
6-5/8 7	5-1/2" Casing Cutter	101951863	5.500	9,000 / 400	275.5	Aluminum	1.4D UN0352	6-5/8 7	L80	0.228 - 0.417 0.408 - 0.540	20.00 - 28.00 29.00 - 38.00
7	6" Casing Cutter	101978741	6.000	9,000 / 400	275.5	Aluminum	1.4D UN0352	7	L80	0.317 - 0.408	23.00 - 29.00
7-5/8	6-1/8" Casing Cutter	101978742	6.125	9,700 / 400	275.5	Aluminum	1.4D UN0352	7-5/8	L80	0.375 - 0.500	29.70 - 39.00
8-5/8	7-1/4" Casing Cutter	101978743	7.250	8,000 / 400	421.0	Aluminum	1.4D UN0352	8-5/8	L80	0.400 - 0.595	36.00 - 52.00
9-5/8 9-7/8	8-3/16" Casing Cutter	101978744	8.188	8,000 / 400	404.8	Aluminum	1.4D UN0352	9-5/8 9-7/8	L80	0.435 - 0.545	43.50 - 53.50 62.80 - 68.00

DRILL COLLAR SEVERING TOOLS

Item	Description	1 3/8-in. OD 15,000 psi	1 3/4-in. OD 15,000 psi	2-in. OD 15,000 psi	2 5/8-in OD 15,000 psi	2 1/8-in OD 26,000 psi	Ship Class
*1	Hardware Kit	100118390	101292915	101292956	101292957	101604779	N/A
2A	Detonator - RED®	101272595	101272595	101272595	101272595	N/A	1.4B UN0255
2B	Detonator - Resistorized, 55ohm	100000432	100000432	100000432	100000432	100000432	1.4B UN0255
3	MDF (2.3g NEC)	100118417	100118417	100118417	100118417	100118417	1.4S UN0367
*4A	Explosive Kit (HMX) Pellets and Cartridges	101214053	101293167	101293168	101293152	101293168	1.4S UN0349
*4B	Explosive Kit (HNS) Pellets and Cartridges	101237459	101293207	101293234	101293235	101293234	1.4S UN0349
6	Firing Head	100118430	100000434	100000434	100000434	100157532	N/A
7A	Extension Mandrel (Included in hardware kit) - 2 ea.	100158260	100008258	100008258	100008258	101539987	N/A
8A	Adapter for RED® Detonator, Aluminum	120042268 (Steel)	101293676	101293676	101293676	N/A	N/A
9	Shunt Plug	100118431	100010861	100010861	100010861	100010861	N/A
10	Protective Holder	100010862	100010862	100010862	100010862	100010862	N/A
11	Loading Tool	100118432	100118432	100118432	100118432	100118432	N/A
12A	DCST Adapter - Aluminum	100157807	100158288	100157816	100158290	101538611	N/A

HP ACCESSORIES (20,000 PSI MAX.)

Item	Description	1 3/8-in. OD	1 3/4-in. OD	2-in.OD	2 5/8-in OD
7B	Ext. Mandrel - Steel	101293225	101293227	101293227	101293227
8B	Adapter for RED® - Steel	120042268	101293230	102193230	101293230
12B	DCST Adapter - Steel	Standard	101293169	101293187	101293220

CENTRALIZING ACCESSORIES FOR PIPE RECOVERY PRODUCTS

Description	Part No.	Important Notes:
Centralizer Body, 1-11/16 in.	72364	1. Hardware kit includes 2 each of item 7 (aluminum). 2. The 26k psi hardware kit includes 1 each of item 7 (steel). 3. Items 6,8,9,10 & 11 must be ordered separately, as required. 4. An additional shock mandrel (Item 7) may be used for added shock protection. 5. For High Pressure High Temperature application, in excess of 15,000 psi, JRC recommends the use of high pressure rated accessories. 6. For 20,000 psi to 26,000 psi use High Pressure DCST.
Bow Spring Max open 13-1/4 in.	72363	
Bow Spring Max Open 9-1/2 in.	114520	
Bow Spring Max Open 6-1/4 in.	72362	
Redress Kit, 1-11/16 in. Centralizer	133004	

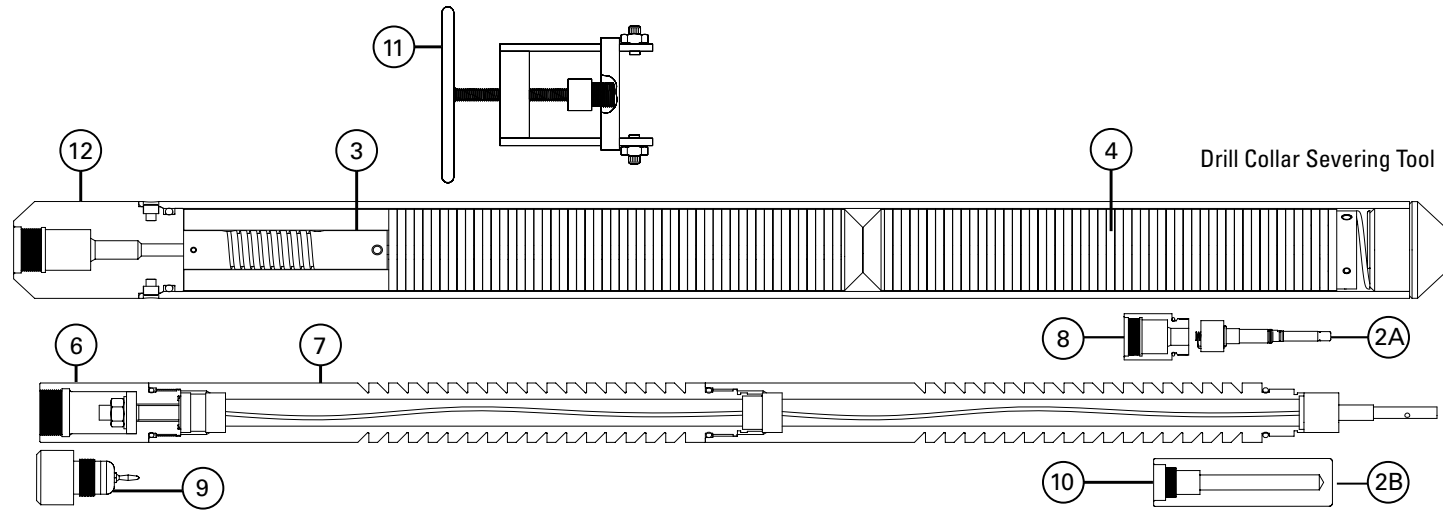

DRILL COLLAR CAPABILITY CHART

Tool OD	1-3/8" (3.5cm)	1 3/4 in. (4.4cm)	2 in. (5.1cm)	2 5/8 in. (6.7cm)	2 1/8 in. (5.4cm)
Temperature	HMX - 400°F (204°C) for 1 hour / HNS - 460°F (238°C) for 1 hour				
Pressure	20,000 psi (138 Mpa) for 1 hour with High Pressure Accessories				26,000psi/1hr.(179.3Mpa)
Length	36 in.	36 in.	36 in.	36 in.	37.78 in
Designed to Sever up to	3.5 in. OD Collar	6.5 in. OD Collar	8 in. OD Collar	11 in. OD Collar	8 in. OD Collar
Explosive Pellet Weight x No. of Pellets	20.7g x 28	22.0g x 44	20.4g x 64	21.0g x 110	20.4g x 64
Cartridge Assy Explosive Weight	4.8g x 2	12.75g x 2	17.4g x 2	22.7g x 2	17.4g x 2
Loaded Tool Weight N.E.C.	589.2g	993.5g	1340.4g	2355.0g	1340.4g



Drill collars and drill pipe severed by JRC drill collar severing tools.



Product Sales, Research, Test and Manufacturing Facility:

Jet Research Center

8432 South I-35W

Alvarado, Texas 76009-9775

T: +1.800.451.5403 or +1.817.761.2000

F: +1.817.761.2240

Branch Office and Warehouse Location:

Jet Research Center

3710 East Rio Grande

Victoria, Texas 77901

T: +1.361.580.3150

F: +1.361.580.3186

Distributors:

For a complete list of distributors,

Please visit www.jetresearch.com



www.jetresearch.com

JRC is ISO 9001; ISO 14001; OHSAS 18001; ISO RC 14001
and OSHA VVP STAR Certified.

Sales of Jet Research products will be in accord solely with the terms and conditions contained
in the contract between Jet Research and the customer that is applicable to the sale.
©2012 Jet Research Center. All Rights Reserved.